

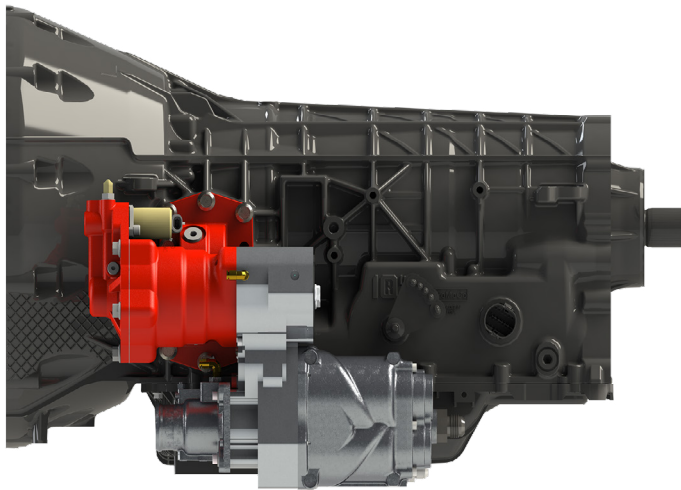

DIRECT-TRANSMISSION MOUNTED AIR COMPRESSORS

DTM70



BENEFITS



Up To 70 CFM. 100% Of The Time.

DTM70 air compressors use patented rotary screw technology designed to run at 100% duty cycle without stopping, so operators don't have to wait for their air compressor to fill an air receiver tank. This maximizes tool performance and eliminates downtime.



Decrease Truck GVW By Up To 260 lb

DTM70 air compressors reduce truck weight by as much as 260 lb because there is no secondary engine to carry around on your truck. At only 150 lb, the DTM70 also weighs a fraction compared to other underdeck air compressors. Choose a lightweight air compressor, and you'll be able to add more tools and equipment to your truck, carry more materials, and take advantage of better fuel economy.

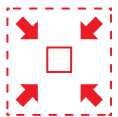

Free Up To 25 Cubic Feet

VMAC DTM70 air compressors free up to 25 cubic feet on the truck deck because the air compressor mounts to the transmission, and the rest of the system mounts under the truck. In fact, no components get installed on the Ford truck deck, ensuring a clean and professional-looking truck and space for other equipment, tools, or materials.



Easy Operation

VMAC's DTM air compressors feature easy-to-use controls. Simply press the on/off button on the digital control box, and the system will take care of the rest; the PTO engages, the compressor turns on, and the throttle control automatically idles the truck engine up and down to match air demand. For cold climate operation, a heater is built into the compressor, which automatically warms up on the way to the job, so it is ready to work when you are.



Easy Installation

DTM70 air compressors are easy to install, with installation times up to 50% faster than other underdeck air compressor systems. The DTM70 doesn't require modifications to the RAM or Ford transfer case, nor drive shafts that can cause alignment issues. Traditional underdeck air compressors for RAM and Ford Super Duty trucks are extremely heavy, have poor ground clearance, and require additional components sourcing. VMAC mounting kits are application engineered for RAM and Ford diesel trucks and include all the necessary components.

COMPONENTS

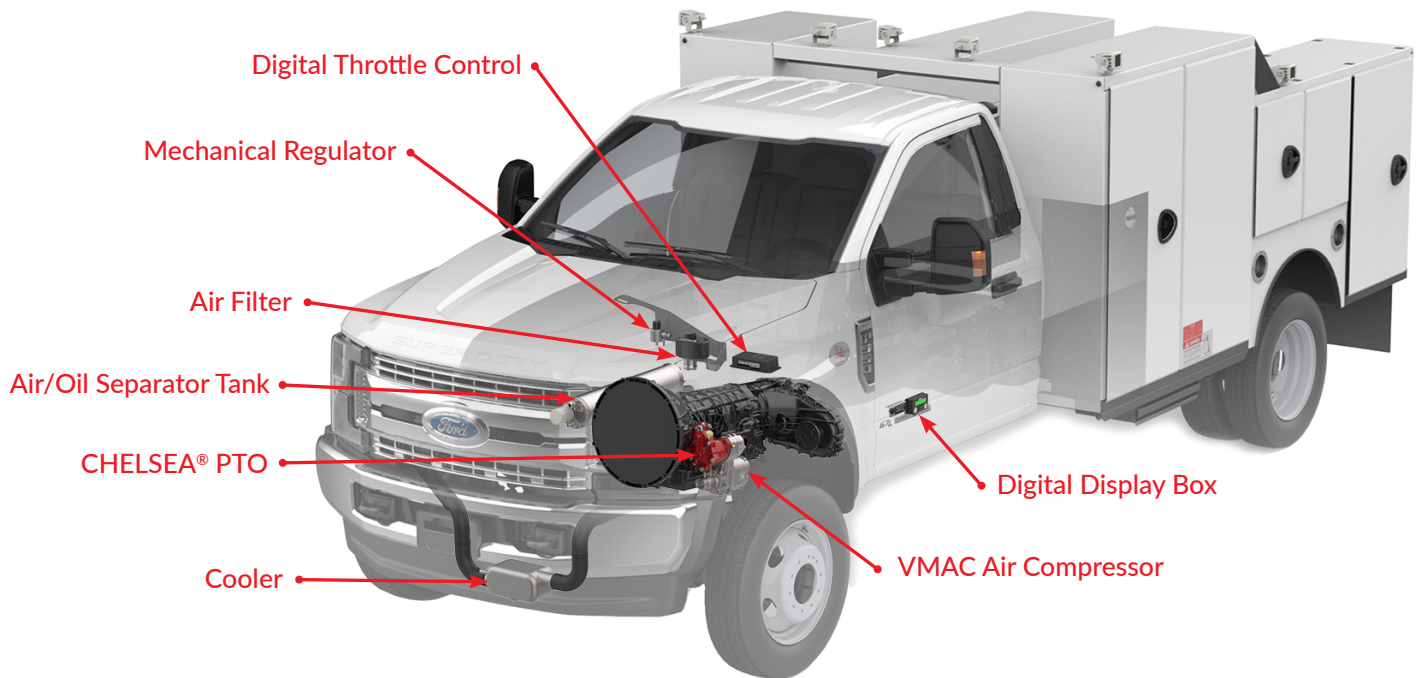

SPECIFICATIONS

Air Compressor Output	Up to 70 CFM @ 100 psi (175 psi max)
Air Compressor Type	PTO driven, direct transmission mounted, 100% duty cycle, VMAC oil-injected rotary screw
Weight (wet)	Approximately 150 lb (68 kg)
PTO (Included)	CHELSEA® PTO; electrically actuated, PTO indicator lamp <ul style="list-style-type: none">» CHELSEA® 272 Series (RAM)» CHELSEA® 210 Series (Ford)
Display Box	<ul style="list-style-type: none">» On/Off function of PTO and compressor» LCD display» Service notifications» Displays error messages and stores error codes» System temperature
Throttle Control	<ul style="list-style-type: none">» Variable speed - adjusts truck engine speed automatically to match air demand» Digital throttle control connects to OBD2 CAN bus connector
Safety System	<ul style="list-style-type: none">» Automatic compressor heater function» Compressor over-temp sensor» Automatic rapid blow-down valve on tank» 200 psi air pressure relief valve» Truck drive disable circuit on throttle control» Truck park brake safety shut-off switch on control box
Applications	<ul style="list-style-type: none">» 2019+ RAM 3500 to 5500 chassis cab 6.7L Cummins diesel with PTO prep package (option code LBN)» 2020+ Ford F250 to F600 Super Duty 6.7L Power Stroke diesel with PTO provision
Warranty	<ul style="list-style-type: none">» Two years on all major components; VMAC air-ends are covered by VMAC's Lifetime Limited Warranty» Chelsea PTO covered by Parker Chelsea Two Year Warranty