



AIR N ARC® 300 HYDRAULIC

-  AIR COMPRESSOR
-  GENERATOR
-  WELDER
-  BATTERY BOOST
-  BATTERY CHARGE

Quiet, Lightweight, One Unit - Five Forms of Power!

The Air N Arc® 300 Hydraulic ALL-IN-ONE Power System® features the innovation of being hydraulically driven, while still offering all the advantages of the Air N Arc® 300 engine drive system including a 40 CFM rotary screw air compressor, 300 AMP welder, 300 AMP 12V charger and 12V/24V booster, and 7 kW generator. Designed as a true two-generator system, the Air N Arc® 300 Hydraulic allows simultaneous dual functionality such as welding and generator for lights. The system offers a small footprint for side pack or behind-the-cab mounting and is ideal for trucks with hydraulics already installed, such as crane trucks.

SPECIFICATIONS	
Drive System	Open Center Hydraulic
Hydraulic Requirements	19 GPM @ 2800 PSI Multifunction/14.5 GPM @ 2500 PSI Single function
Air Compressor	Rotary Screw, 40 CFM, 175 PSI
Welder	High Frequency DC Welding, 270 AMPs at 100% Duty Cycle CC: 40-300 AMPs Operating Range, CV: 15-30 Volts
Generator	7 kW Peak / 6.8 kW Continuous, AC Power, 60 Hz, Single Phase, 120V and 240V Outlets
Battery Charger/Booster	300 AMPs 12V/24V Boost, 50 AMP 12V Charge

Air N Arc® 300-H Unit Dimensions with Fittings (In.):
48.7L X 21W X 30.9H | Dry Weight with Control Panel (Lbs.): 621

* Ratings are approximate and are based on 120 °F hydraulic fluid temperature. Add 400 PSI minimum to hydraulic requirements for hydraulic system continuous pressure ratings. Consult Vanair® for specific details.



AIR NARC® 300 HYDRAULIC

FEATURES

- Single Function 14.5 GPM Model is Suitable for Ford® 4X4 Super Duty and Dodge® Trucks
- True Two-Generator System for Safe Multifunction of Welder and Electric Tools
- Small Footprint - Will Fit on Side Pack or Behind Cab
- Integrated Hydraulic Cooler
- CV MIG Capability
- One Unit to Start all Your Equipment with Battery Charge and Boost Capability
- Rotary Screw Air Compressor for Air on Demand
- Heavy Duty Belt Drive System for Anti-vibration and Long Service Intervals
- Integrated Lift Hook
- Designed with Hinged Lid for Easy Maintenance
- Powder Coated Sheet Metal

AIR COMPRESSOR

- Rotary Screw Compressor - Encapsulated
- 40 CFM @ 150 PSI
- 175 Max PSI

WELDER

- High Frequency DC Welding
- 270 AMPs at 100% Duty Cycle
- CC Range 40 – 300 AMPs Operating Range
- CV Range 15 – 30 Volts
- Independent DC Welder
- Safe Multi-Function

GENERATOR

- 7 kW Peak / 6.8 kW Continuous @ 60 Hz
- Independent AC Power for Safe Multi-functioning
- Brushless Design
- Smooth Wave for Minimal Distortion
- Two-120V Outlets and One-240V Outlet

HYDRAULIC SYSTEM REQUIREMENTS

All hydraulic ratings and pressures are at the machine and do not take into account the pressure drops of individual hydraulic systems. These pressure drops need to be taken into account and added to the rating of the hydraulic pump and components. Vanair highly recommends consulting a hydraulic supply expert for specifying the correct hydraulic pump size and type, oil reservoir size, hydraulic cooler, hydraulic pressure relief, and other hydraulic supply components for your application. Please take into consideration the following: The hydraulic flow and pressure requirements of the air compressor, the continuous hydraulic load when the compressor is running, the duty cycle and ambient operating temperatures, and any other hydraulic equipment that may share the same hydraulic supply system (Vanair recommends a dedicated pump and hydraulic circuit).

Vanair reserves the right to make changes in engineering, design, and specifications; add improvements; or discontinue manufacturing at any time without notice or obligation. Vanair, the Vanair logo and MOBILE POWER SOLUTIONS are registered trademarks or trademarks of Vanair Manufacturing, Inc., Michigan City, IN, USA. © 2022 All Rights Reserved.

BATTERY BOOST/CHARGE

- 300 AMP 12V/24V Boost
- 50 AMP 12V Charge

REMOTE CONTROL PANEL

- Provides Ultimate User Convenience and Safety
- All Functions Accessible at Panel No Need to Jump In and Out of Vehicle

OPTIONS/ACCESSORIES

- Welding Cables - 25', 50'
- Welding Helmet with Auto Darkening Lens
- Battery Booster Cables
- Cable Extension Segment
- Remote Air Tank – 30 Gallon
- Remote Condensation Drain
- Maintenance Kits
- Welding Rods
- Compressor Air Inlet Heater
- Hose Reels and Fittings

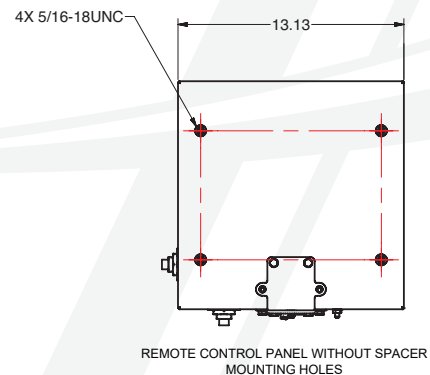
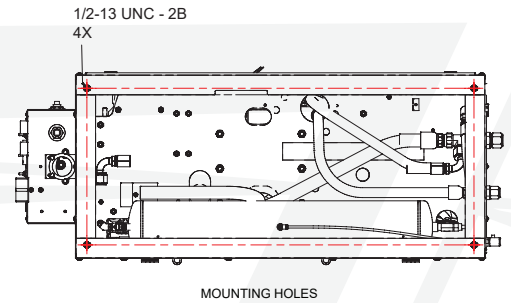
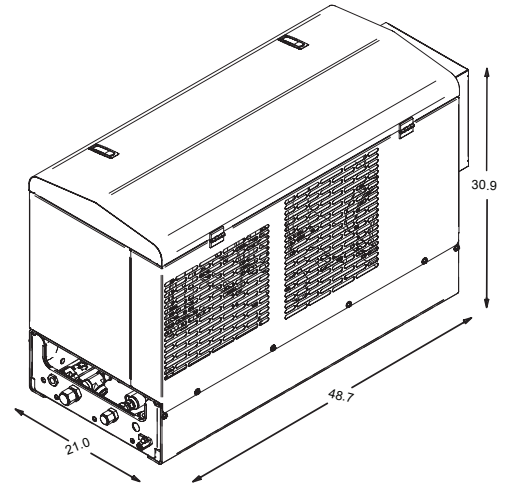

VANAIR
MOBILE POWER SOLUTIONS®

800.526.8817 | vanair.com

10896 West 300 North | Michigan City, Indiana 46360 USA



ANA300H_03172022_NML